



A stable ground for any space

AQUAPANEL® Cement Board Floor

AQUAPANEL® Cement Board Floor

The new generation of AQUAPANEL® floor systems provides architects and construction professionals with a superior alternative to wet screeds, which can be used for any type of floor constructions.

Today's extremely high demands regarding daily use, durability and easy installation make these systems the favourite choice. Therefore the first cement screed without water brings more flexibility for innovations to your floorings – an important step forward in the field of ready-to-use floor screeds.

It can be applied in private homes and public buildings such as offices, schools and hospital, in large or small areas, and in new builds and renovations.



Contents

System overview	4 – 5
Transportation and storage	6
Preparatory work	7 – 9
Installation	10 – 11
Floor coverings	12
Construction overview	14 – 19
Load-bearing capacity	20
Combination with floor heating	23
Application fields	24
Construction details	26 – 29
Technical product details	31

AQUAPANEL® Cement Board Floor/MF – a superior, faster alternative to both wet and dry screeds:

- *Best sound and thermal insulation*
- *Particularly suitable for tiles*
- *Recommended for all types of parquet*
- *Floor system with innovative slot edge*
- *Easy and fast installation*
- *Provides the perfect floor structure, when used with AQUAPANEL® Levelling Fill*
- *Coverings can be placed 12 hours after laying*
- *Suitable for underfloor heating systems, up to 70 °C*
- *100 % completely water-resistant*
- *100 % mould-resistant*
- *Durable and stable with high load capacity*

System overview

AQUAPANEL® Cement Board Floor/MF

Boards

AQUAPANEL® Cement Board Floor

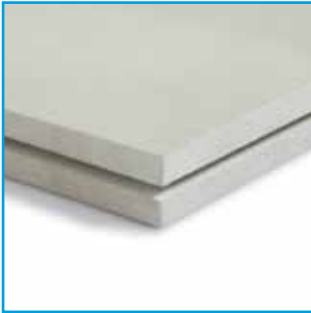

Cementitious dry floor panel

Dry floor component made from Portland cement with aggregate. Rectangular edge with all-round milled slot allows end-to-end gluing together of panels.

Thickness: 22 mm
Length: 900 mm
Width: 600 mm
Panel dimensions: 900 x 600 mm
Weight: Approx. 37 kg/m²
Packaging: 50 pieces/pallet (27 m²)

AQUAPANEL® Cement Board Floor MF

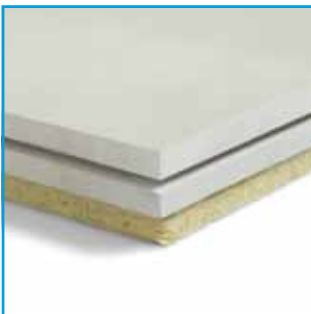

Cementitious dry floor panel laminated with impact sound insulation board

Dry floor component made from Portland cement with aggregate. Rectangular edge with all-round milled slot allows end-to-end gluing together of panels. AQUAPANEL® Cement Board Floor MF additionally features a 10 mm mineral fibre insulation underneath.

Thickness: 33 mm
Length: 900 mm
Width: 600 mm
Panel dimensions: 900 x 600 mm
Weight: Approx. 39 kg/m²
Packaging: 50 pieces/pallet (27 m²)

Accessories

AQUAPANEL® Slot Adhesive (PU)



AQUAPANEL® Slot Adhesive (PU) is a polyurethane adhesive that is applied to the edges of the panels. It is used in floor applications for bonding individual AQUAPANEL® Cement Board Floor and AQUAPANEL® Cement Board Floor MF boards together.

Coverage: Approx. 60 ml/m²
Cartridge contents sufficient for approx. 5 m²

Packaging: 310 ml/cartridge
20 cartridges/box

Accessories

AQUAPANEL® Biscuit



The AQUAPANEL® Biscuit has been specially developed for joining and levelling AQUAPANEL® Cement Board Floor and Floor MF panels. The biscuit is made of break-proof, translucent plastic. The dimensions of the biscuit are: w/l/h = 60 x 23 x 4 mm. The AQUAPANEL® Biscuit has an elliptical shape. Ridges across

the width as well as ridges around the edges give the biscuit high stability. Being precisely manufactured, the biscuit can be easily inserted into the close-fitting slot of the floor panel. Border panels can be easily aligned. Inserting the biscuit has a self-levelling effect so the floor panels create a level surface when laid.

Coverage:
Approx. 7 biscuits per m²
Thickness: 4 mm
Length: 60 mm
Width: 23 mm
Packaging:
100 pieces/box
200 pieces/box

AQUAPANEL® Board Primer



AQUAPANEL® Board Primer is a ready-to-use synthetic dispersion for priming AQUAPANEL® Cement Board Floor and Floor MF and guaranteeing maximum adhesion of floor coverings.

Coverage:
Approx. 50 g/m²
Processing time:
Approx. 1 Minute/m²
Processing temperature:
Above +5 °C
Dilution:
1:1 with water

Packaging:
2.5 kg/pail
15 kg/pail

AQUAPANEL® Levelling Compound



AQUAPANEL® Levelling Compound is a frost-safe, powder-form floor plaster which, after mixing, is self-levelling thus ensuring an evenly plastered surface. It provides plane levelling of AQUAPANEL® Cement Board Floor dry underfloors under thin

soft coverings and equalises unevenness in cement and poured screed, bare concrete floors, masonry and wooden floors of 2-15mm depth. It is particularly suitable for levelling areas subject to large temperature variations such as screeds with floor heating.

Coverage:
Approx. 1.5 kg/m²/mm
Processing temperature:
From +5 °C to +25 °C
Packaging:
25 kg/bag

AQUAPANEL® Levelling Fill



AQUAPANEL® Levelling Fill is ideal for height levelling, fire protection, heat insulation and impact sound resistance.

Grain size:
d = 0 - 7 mm
Bulk density:
ps = ca. 140 kg/m³
Weight per unit area (built):
1.54 kg/m² per cm of depth
Thermal conductivity:
λ = 0.060 W/(m·K)

Building material class: B2
in accordance with DIN 4102
Compressive strength (compressive strain at 10% compression): ≥ 90 kPa
Permit No.: Z-23.11-1286
Packaging: 100 l/bag

Transportation and storage

The ideal handling

Always carry AQUAPANEL® Cement Board Floor panels by the top edge, or transport them using a stacker truck or board truck. When unloading, take care not to damage the corners and edges. If AQUAPANEL® Cement Board Floor is not stored properly it may deform. This takes up valuable fitting time and can result in faults. Correct storage: fully-flat on an even base or on timber battens 25 cm apart.

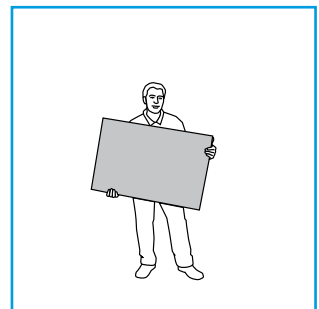

To avoid unwanted deformation, protect AQUAPANEL® Cement Board Floor from moisture and weathering right up until the time it is fitted. Where boards have become damp prior to fitting, they must - without exception - be dried on both sides while laid flat on an even surface.

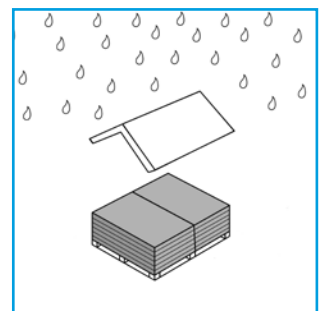

Make sure you know the load-bearing capacity of the subsurface. A pallet of AQUAPANEL® Cement Board Floor loads the floor structure by around 1000 kg.

Climatic conditions (state of air in the room) before, during and after laying AQUAPANEL® Cement Board Floor:

- Relative humidity $\leq 85\%$
- Room and material temperature $\geq +5\text{ }^{\circ}\text{C}$.

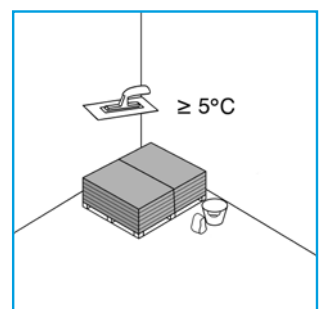

AQUAPANEL® Cement Board Floor must be acclimatised to the conditions described above before laying. The moisture content must be at most 5.5 M-%.

Preparatory work

AQUAPANEL® Cement Board Floor/MF

Select fill

The universal AQUAPANEL® Levelling Fill is ideal for height levelling, fire protection, heat insulation and impact sound protection.

Determine any height differences

Using a spirit level or a laser device, place the ruler as a point of reference. Then establish the highest point of the floor and determine the height difference in the room.

Calculate depth of fill

Establish the desired finished height of the fill. At the highest point, the depth of the fill must be at least 1 cm. There must also be a covering of 1 cm over open pipework. Determine the depth of fill by considering compaction as follows: depth of AQUAPANEL® Levelling Fill = finished depth x 1.10. The templates are aligned to this depth later.

Mark depth of fill

Now mark the depth of fill at a maximum distance of 2 m on the wall.

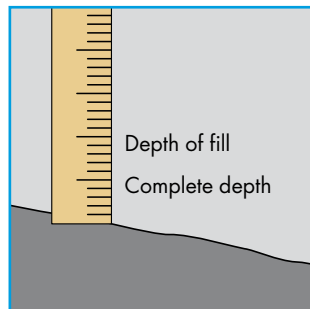

Preparation of the subsurface

Structural prerequisites

AQUAPANEL® floor constructions require a dry and load-bearing subsurface. Rising components, which will be plastered later, must be rendered before laying the insulation layer.

Preparation of wood joist ceilings

Screw down loose or creaking boards and saw through locally squeaking tongue and groove joints. Larger openings must be closed, or covered in a sufficiently stable manner.

A barrier is required to prevent the filler from flowing through holes, notches or joints in the space between the beams. If the physical conditions of the structure do not require a vapour control layer, a material (e.g. paper) open to diffusion can be used for the barrier.

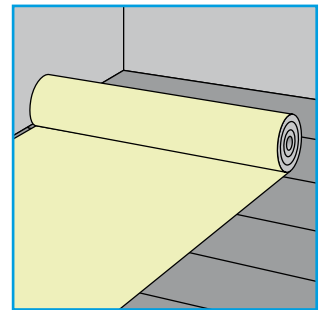

Preparation for solid ceilings

Solid ceilings contain moisture which must be prevented from rising into the floor structure. PE film is employed to do this in floor structures. The pieces of film should be laid flat and should overlap at least 20 cm on joint locations. They must be drawn up over the rising components. Unless you know for sure that the floor structure contains no residual moisture, you must lay this film.

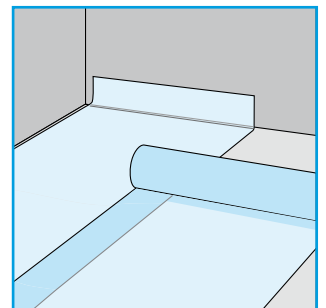

Floorboards in contact with the ground

For floor boards in contact with the ground (cellar bases, buildings without cellars), sealing of building work is required to protect against the penetration of moisture, according to local building regulations.

Preparatory work

AQUAPANEL® Cement Board Floor/MF

Lay loose fill

Fit stop board

To ensure that the material cannot "run away", set a stop board in the door frame (80 - 100 mm wide). It must be as high as the fill in its compacted condition.

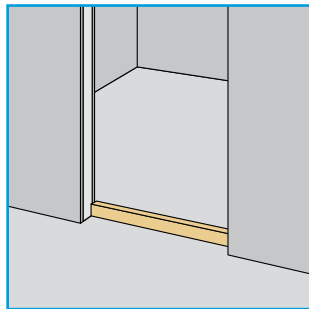

Apply fill from the window to the door

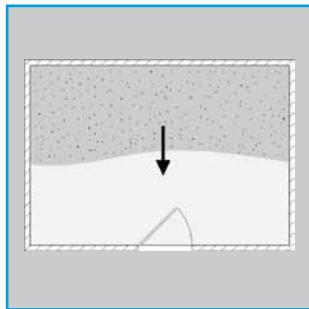

Align templates

Start at the wall furthest away from the door. Place a strip of fill about 25 cm wide along the wall up to the marked depth of fill (top point). Put in a second auxiliary strip 2.5 m away from the first strip.

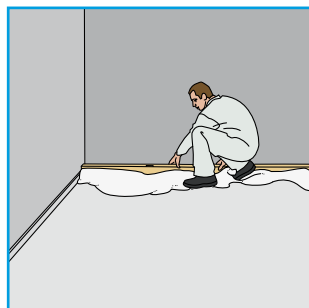

Laying the fill

Fill the area between both template layers with AQUAPANEL® Levelling Fill. But use no more than you will be able to remove without treading on the fill.



Removing the fill

Then remove the fill with the removal template. In doing so, always work from the side of the room furthest away from the door. Do not tread on the fill. For niches, wall protrusions and other edge areas, obtain the required marking height using a float or a short removal template. Only remove the fill. Do not compact the existing fill by tamping.



Laying diagram

Specify direction of laying

If wooden flooring is to be laid on the finished dry floor, the direction of laying must be established before laying the dry floor. Strip flooring is normally laid perpendicular to the dry floor, with parquet flooring in a fishbone pattern and mosaic parquet at an angle of 45 degrees.

Lay cover boards from the door to the window

Use as cover boards either a gypsum plasterboard in accordance with DIN EN 520 or a mineral wool impact sound insulation board in accordance with DIN EN 13162 or a soft fibre board (WF) in accordance with EN 13171.

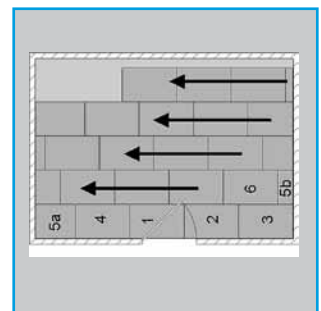

Lay dry floor from the window to the door

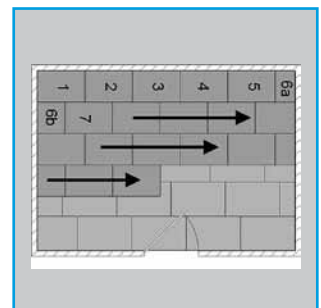

Lay strip flooring at an angle of 90°, fishbone parquet at an angle of 45° to the dry floor.

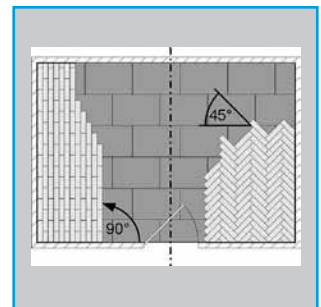

Fill and cover boards

Selection of cover boards

For planned fill depths of up to 60 mm, plasterboard according to DIN EN 520 or impact sound insulation board may be used as alternatives (see p. 14). For depths of fill over 60 mm, because of the mechanical compaction, a more robust plasterboard or fibreboard should always be used. Plasterboard, fibreboard and mineral wool insulation boards are also referred to as cover boards below.

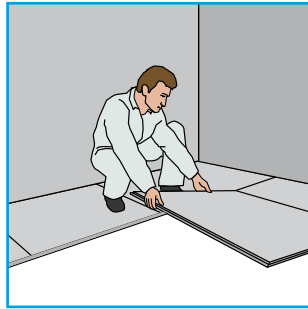

Cut cover boards

Cut cover boards to fit with a knife and lay on the fill. Use sections in lengths or widths of more than 20 cm. Lay cover boards from the door into the room. Lay each further board from above straight down onto the fill so that the surface remains plane and level. Lay the cover boards flush against the wall and butt the ends. Avoid crossovers and ensure joint staggering of 20 cm.

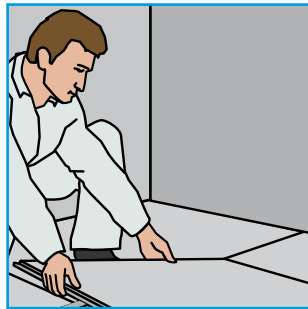

Fill depth up to 60 mm

Compact fill up to a depth of 60 mm by walking on the entire surface of the cover board, including the wall and corner areas.

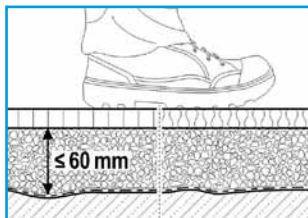

Depth of over 60 mm and up to 200 mm

Over a 60 mm depth of fill, the fill must be mechanically compacted. To protect against damage, lay shuttering panels or strips of chipboard on the cover boards. Then mechanically compact the fill using a hand rammer or an electric floor compactor. Take account of compaction size.

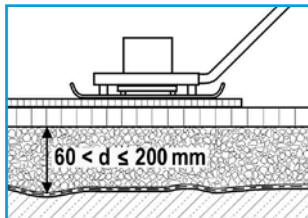

Compacting with a hand rammer.



Compacting with an electric floor compactor.



Depth of fill over 200 mm

Compact fills to a depth of greater than 200 mm in several passes. Lay on shuttering panels for each layer. Then mechanically compact the fill using a hand rammer or an electric floor compactor. Repeat compaction as needed. Cover boards remain in the construction. Remove shuttering panels.

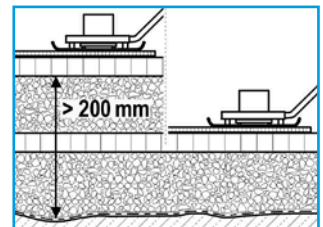

Installation

AQUAPANEL® Cement Board Floor/MF

Laying the first board

The first AQUAPANEL® Cement Board Floor panel is fitted in the corner of the room.

Insert wedges when doing this to avoid the first boards becoming displaced by pushing in of subsequent components. When placing the wedges ensure that a 10 mm edge insulation strip can later be installed.

The finished components must be laid over almost the entire subsurface.

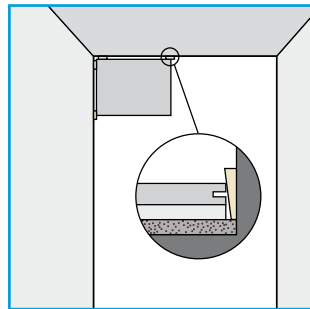

Lay according to diagram

The last AQUAPANEL® Cement Board Floor of each row should be cut to fit (A). Start a new row with the offset (B). In this way you obtain the necessary joint staggering (min. 20 cm).

Installation is possible either from left to right or in the opposite direction.

Always work from window to door. Avoid cross joints.

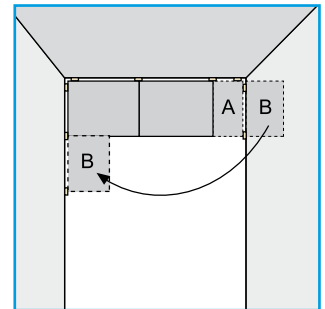

Laying subsequent components

Before applying AQUAPANEL® Slot Adhesive (PU), clean the slot edge of the AQUAPANEL® Cement Board Floor panel with a damp brush to remove dust. Cleaning of the edges is a prerequisite for a tight-fitting joint and firm bonding of the components.

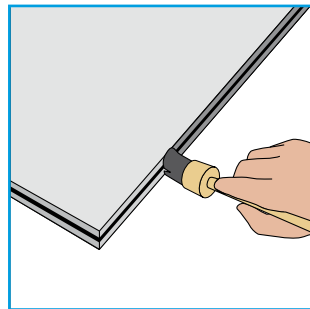

Formatting

To cut AQUAPANEL® Cement Board Floor and ensure smooth cut surfaces, use a handheld circular saw with a dust extractor, e.g. FESTO TS 55 Q plus FS, with a diamond saw blade. If using a pendulum jigsaw, we recommend a carbide-tipped saw blade, e.g. Bosch T141 HM.

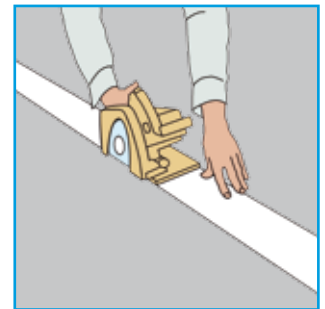

Apply adhesive

Apply AQUAPANEL® Slot Adhesive (PU) to the grooved edge of the panel using the special application nozzle. The adhesive will emerge as a wide, thin strip and cover the slot.

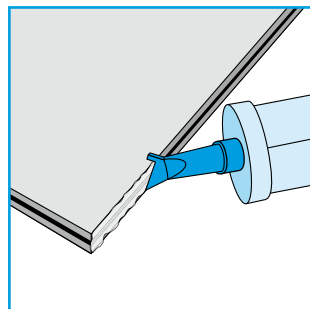

Coverage: 60 ml/m²

Open time: Approx. 80 min.

Working temperature: ≥ +5 °C

Insert biscuits

After applying the AQUAPANEL® Slot Adhesive (PU), push the AQUAPANEL® Biscuit into the slot through the "adhesive curtain". The adhesive, which also fixes the biscuit as it hardens, is pushed into the slot as a result of this process.

The position of the biscuit can be obtained from the layout diagram (see next page).

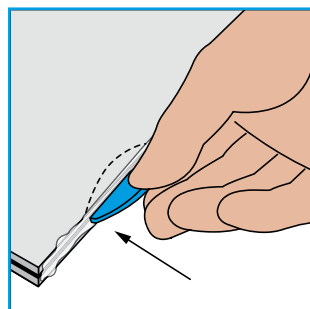

Coverage: Approx. 7 per m²

Laying and bonding

Push the longitudinal and wide sides of the AQUAPANEL® Cement Board Floor panels together, so the AQUAPANEL® Slot Adhesive (PU) emerges to the surface. In doing this, the AQUAPANEL® Biscuits are pushed into the slot in the board.

If the room is longer than 10 m, expansion joints in the surface are necessary.

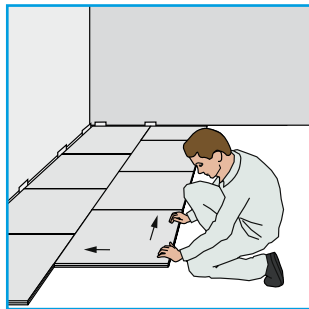

Ensure offset

When laying panels, take care that no cross joints result. Butt joints must be offset by a minimum of 20 cm and always fixed with an AQUAPANEL® Biscuit. If needed, use an additional biscuit.

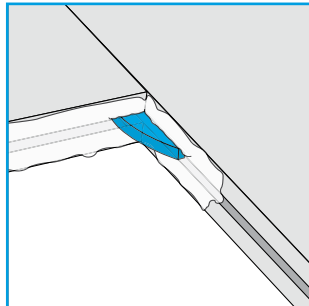

Layout diagram for the biscuits

AQUAPANEL® Biscuits are installed in pairs on the short side of the finished floor panels and in threes along the long edge of the boards. The biscuits are placed so that the neighbouring board at the end of a joint is fitted with a biscuit. The biscuits are installed perpendicularly to the joint of the already laid boards (see image).

There must be no cross joints. Fitting of a biscuit into a cross joint is not permitted.

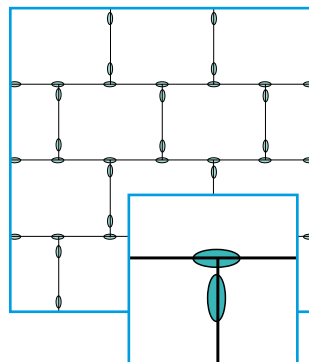

Finishing laying

The last cut-to-size AQUAPANEL® Cement Board Floor panel is first tilted on one side, attached, and then "dropped". Then press the panel in both directions until adhesive emerges onto the surface.

The AQUAPANEL® Cement Board Floor panel can be pushed by hand, but tool assistance, e.g. a nail puller, may also be used.

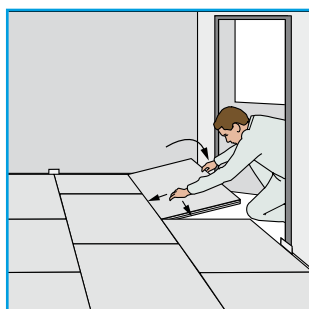

Scrape off the adhesive

After the adhesive has hardened (about 12 hours), scrape off any excess material.

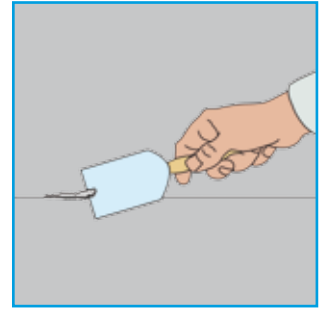

Priming

The entire, cleaned surface must be primed with AQUAPANEL® Board Primer immediately after the adhesive has hardened, approx. 12 hours after laying.

Coverage: 50 g/m²



Floor coverings

Parquet flooring, tiles & natural stone, textile, PVC, linoleum

Because of its manufacturing accuracy and stability of form, AQUAPANEL® Cement Board Floor is particularly well suited for laying of tiles, boards and parquet flooring. Tile and parquet flooring can generally be laid directly. Refill joints if necessary. Take into account the drying time of the filling material.

Moisture loading

For floor areas in domestic bathrooms, which receive light water spray only briefly and occasionally, only the edge joint needs to be sealed with sealing tape. Sealing of the entire surface is not required.

Parquet flooring

The Institute of Flooring Engineering expressly recommends AQUAPANEL® Cement Board Floor for the laying of fully self-adhesive solid parquet.

AQUAPANEL® Cement Board Floor is suitable for use as a subsurface for virtually all types of parquet, from floating ready-made parquet over laminate, to fully self-adhesive solid parquet. If necessary refill joints. When selecting the parquet floor adhesive, all adhesives recommended by the parquet floor manufacturer are suitable, such as:

- Synthetic resin, dispersion wood floor adhesives
- Reaction resin wood floor adhesives
- Powder adhesives
- Polymer adhesives

The parquet flooring must be arranged perpendicular to the laying direction of the AQUAPANEL® Cement Board Floor. For laying parquet in a fishbone pattern, the angle between the laying directions is 45° (see p. 8). When laying parquet, refer to the local building regulations, as well as guidelines of the parquet flooring trade and the manufacturer's data.

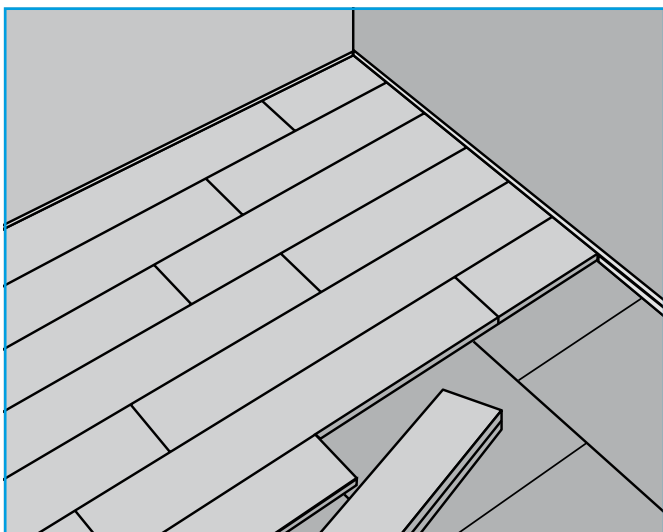

Tiles and natural stone

Ceramic coverings can generally be directly stuck on using a thin bed of cement. If necessary refill joints. The covering must be suitable for laying in a thin bed, and must be laid with "open joints". Flexible setting adhesives (plastic-coated cement powder adhesive) and jointing mortar are appropriate. The tile adhesive must meet C2 requirements (adhesion $\geq 1.0 \text{ N/mm}^2$) to DIN EN 12004 and S1 (bending displacement $\geq 2.5 \text{ mm}$) to DIN EN 12002. Seal edge joints with elastic jointing material.

The maximum side length of ceramic coverings is 33 x 33 cm. For larger formats, an isolation underlay mat must be used. When laying ceramic coverings, please refer to manufacturer's data together with the further guidelines for tiling work. The local building regulations should be followed.

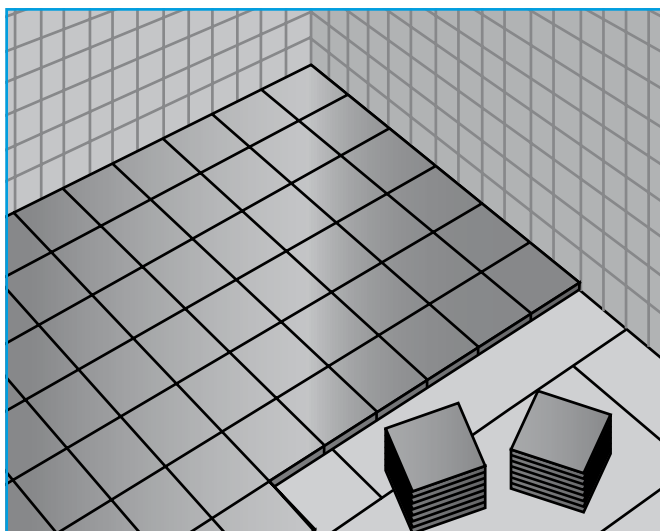

Textile, PVC, linoleum

For coverings made of textiles, PVC and linoleum, apply AQUAPANEL® Levelling Compound over the entire surface before laying. To prevent the material from penetrating into the substrate, close gaps in the flooring surface beforehand with filler as appropriate. Only lay the floor covering after the screed is completely dry. By levelling, you prevent the joint areas of the components or other minor unevenness later appearing in the floor covering. Carpets should be fixed with double-sided adhesive tape or with a repositionable adhesive system applied over the entire surface. It is then possible to remove the covering later without leaving a residue.

When laying, follow the local building requirements, the further guidelines for tiling work and the manufacturer's specifications.



Construction overview

AQUAPANEL® Cement Board Floor

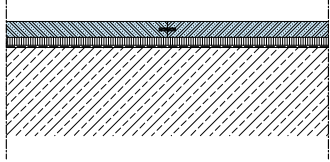
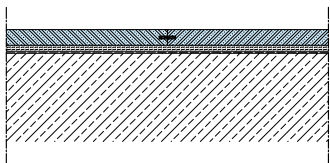
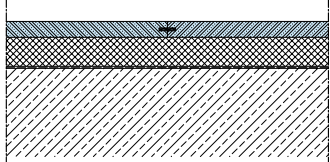
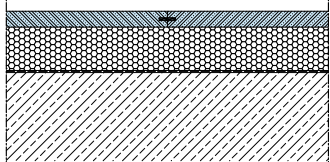
	Drawing	System	Depth of layer	Load-bearing capacity	
				Area load	Concentrated load
Direct installation		AQUAPANEL® Cement Board Floor Impact sound insulation board (on solid ceiling)	22 mm 12-1 mm	3,0 kN/m ²	3,0 kN
		AQUAPANEL® Cement Board Floor Fibreboard (on solid ceiling)	22 mm 8 mm	3,0 kN/m ²	3,0 kN
		AQUAPANEL® Cement Board Floor WF DEO ≥ 100 kPa (on solid ceiling)	22 mm ≤ 60 mm	3,0 kN/m ²	3,0 kN
		AQUAPANEL® Cement Board Floor EPS DEO ≥ 150 kPa (on solid ceiling)	22 mm ≤ 60 mm	3,0 kN/m ²	3,0 kN



Construction overview

AQUAPANEL® Cement Board Floor

	Drawing	System	Depth of layer	Load-bearing capacity	
				Area load	Concentrated load
On levelling fill		AQUAPANEL® Cement Board Floor Impact sound insulation board AQUAPANEL® Levelling Fill (on solid ceiling)	22 mm 12-1 mm ≤ 60 mm	3,0 kN/m ²	3,0 kN
		AQUAPANEL® Cement Board Floor Fibreboard AQUAPANEL® Levelling Fill (on solid ceiling)	22 mm 8 mm ≤ 200 mm	3,0 kN/m ²	3,0 kN
		AQUAPANEL® Cement Board Floor WF DEO ≥ 100 kPa Fibreboard AQUAPANEL® Levelling Fill (on solid ceiling)	22 mm ≤ 60 mm 8 mm ≤ 100 mm	3,0 kN/m ²	3,0 kN
		AQUAPANEL® Cement Board Floor EPS DEO ≥ 150 kPa Fibreboard AQUAPANEL® Levelling Fill (on solid ceiling)	22 mm ≤ 60 mm 8 mm ≤ 100 mm	3,0 kN/m ²	3,0 kN
		AQUAPANEL® Cement Board Floor Impact sound insulation board Fibreboard AQUAPANEL® Levelling Fill (on solid ceiling)	22 mm 12-1 mm 8 mm ≤ 100 mm	3,0 kN/m ²	3,0 kN
		AQUAPANEL® Cement Board Floor Fibreboard AQUAPANEL® Levelling Fill (on joist ceiling type 1)	22 mm 8 mm 30 mm	3,0 kN/m ² (Load-bearing capacity of ceiling must be observed)	3,0 kN (Load-bearing capacity of ceiling must be observed)
		AQUAPANEL® Cement Board Floor Fibreboard AQUAPANEL® Levelling Fill (on joist ceiling - exposed beam)	22 mm 8 mm 60 mm	3,0 kN/m ² (Load-bearing capacity of ceiling must be observed)	3,0 kN (Load-bearing capacity of ceiling must be observed)

Sound insulation		
Evaluated sound insulation measurement $R_{w,R}$	Assessed standard impact noise level $L_{n,w,R}$	Impact sound improvement measurement $\Delta L_{w,R}$
65 dB	44 dB	28 dB
	no values available	
	no values available	
	no values available	
	no values available	
62 dB	45 dB	13 dB
47 dB	66 dB	no value available

Construction overview

AQUAPANEL® Cement Board Floor MF

	Drawing	System	Depth of layer	Load-bearing capacity	
				Area load	Concentrated load
Direct installation		AQUAPANEL® Cement Board Floor MF (on solid ceiling)	33 mm	3,0 kN/m ²	3,0 kN
		AQUAPANEL® Cement Board Floor MF (on joist ceiling type 1)	33 mm	3,0 kN/m ² (Load-bearing capacity of ceiling must be observed)	3,0 kN (Load-bearing capacity of ceiling must be observed)
		AQUAPANEL® Cement Board Floor MF (on joist ceiling - exposed beam)	33 mm	3,0 kN/m ² (Load-bearing capacity of ceiling must be observed)	3,0 kN (Load-bearing capacity of ceiling must be observed)
		AQUAPANEL® Cement Board Floor MF (on joist ceiling type 2)	33 mm	3,0 kN/m ² (Load-bearing capacity of ceiling must be observed)	3,0 kN (Load-bearing capacity of ceiling must be observed)
On levelling fill		AQUAPANEL® Cement Board Floor MF Fibreboard AQUAPANEL® Levelling Fill (on solid ceiling)	33 mm 8 mm ≤ 100 mm	3,0 kN/m ²	3,0 kN

Wood joist ceilings

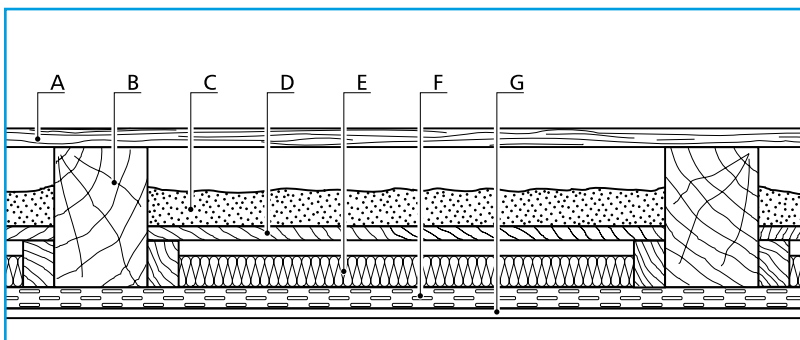

Key

- A Wood boards, d = 21 mm
- B Wood joist 120/180 mm, spacing 62.5 cm
- C Sand filling, d = 50 mm
- D Blind floor, chipboard, d = 19 mm
- E Mineral fibre insulation boards, d = 40 mm
- F Spring tracks, d = 27 mm
- G Knauf gypsum plasterboards, d = 12.5 mm

Sound insulation		
Evaluated sound insulation measurement $R_{w,R}$	Assessed standard impact noise level $L_{n,w,R}$	Impact sound improvement measurement $\Delta L_{w,R}$
58 dB	52 dB	21 dB
61 dB	51 dB	8 dB
40 dB	81 dB	no value available
57 dB	56 dB	6 dB
no values available		

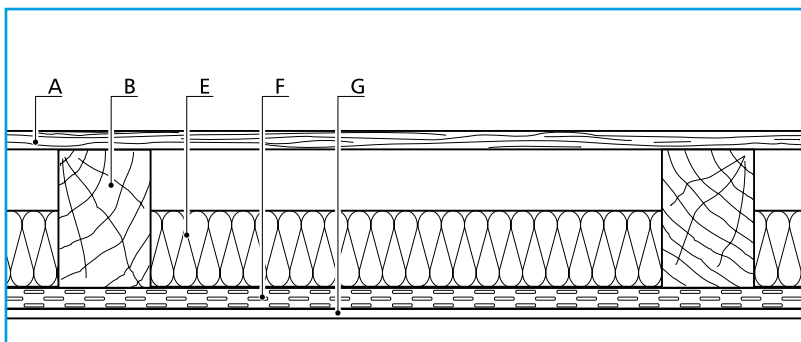

Key

- A Wood boards, d = 21 mm
- B Wood joist 120/180 mm, spacing 62.5 cm
- E Mineral fibre insulation boards, d = 40 mm
- F Spring tracks, d = 27 mm
- G Knauf gypsum plasterboards, d = 12.5 mm

Load-bearing capacity

Load-bearing capacity of dry floor constructions

To determine the load-bearing capacity, it is important to consider evenly-distributed loads and concentrated loads due to people, furniture, equipment, quantities of goods etc. Depending on the relevant loading, AQUAPANEL® Floor Systems have a good load-bearing performance – particularly for use in domestic and administrative buildings. Dry floor constructions are not suitable for driven loads.

Point loads

The sum of point loads must not exceed the maximum permitted floor loading per square metre. For concentrated loads, additional consideration should be given to the formation of standing areas. We would be happy to advise you.

Loads during the building period

Loads which exceed the permitted values should not be considered, even for a short time. Therefore, the construction progress should be planned so that the dry floor is not affected by other works. If larger loads are required because of building activities, relevant protective measures should be taken.

Guidelines for useful loads and areas of use

Use	Area load	Concentrated load
1 Rooms and halls in residential buildings, hospital wards, hotel rooms including their kitchens and bathrooms	2.0 kN/m ²	1.0 kN/m ²
2 Halls in office buildings, office areas, doctor's surgeries, station waiting rooms, recreation rooms including halls, salesroom areas up to 50 m ² , ground floor areas in residential, office and similar buildings	2.0 kN/m ²	2.0 kN/m ²
3 Halls in hospitals, hotels, old people's homes, kitchens and treatment rooms including operating theatres without heavy equipment	3.0 kN/m ²	3.0 kN/m ²
4 Areas with tables, e.g. schoolrooms, cafés, restaurants, dining halls, reading rooms, reception rooms.	3.0 kN/m ²	4.0 kN/m ²
5 Areas with fixed seating, e.g. areas in churches, theatres or cinemas, conference halls, lecture theatres, meeting rooms, waiting rooms.	4.0 kN/m ²	4.0 kN/m ²





Combination with floor heating

AQUAPANEL® Cement Board Floor

AQUAPANEL® Cement Board Floor is particularly well suited for combination with floor heating systems because of its mineral composition and thermal conductivity of 0.79 W/(mK). As a cement board panel, AQUAPANEL® Cement Board Floor is resistant to a higher flow temperature of up to 70 °C compared with gypsum-based dry floors. Any fire resistance classes of the floor are unaffected by installation of floor heating.

Suitable systems

AQUAPANEL® Cement Board Floor is suitable for:

- Electric heating systems, such as heating wires in the adhesive bed of the ceramic covering.
- Heating systems using water pipes. These consist of mould plates made of PS or PUR to take heating pipes close to the surface and a heat-conducting layer for surface transmission of the heat. The mould plates make it possible to lay a complete dry floor.

Clear separation of work

With dry floors, unlike wet floors, there is a clear division between the work of the floor layer and the heating system contractor. This avoids inconsistencies in design and issues with warranties.

Thermal properties of AQUAPANEL® Cement Board Floor

Thermal conductivity is 0.79 W/(mK). All flow temperatures complying with the floor heating manufacturer's specifications are possible.

Reference heating is not required. However, to optimally acclimatise all building materials to the eventual usage temperature, the temperature of the floor heating should be gradually increased before applying the upper layer.

When using isolation systems and underlays beneath floor coverings, make sure you consider the effect on heat transfer through the floor structure.

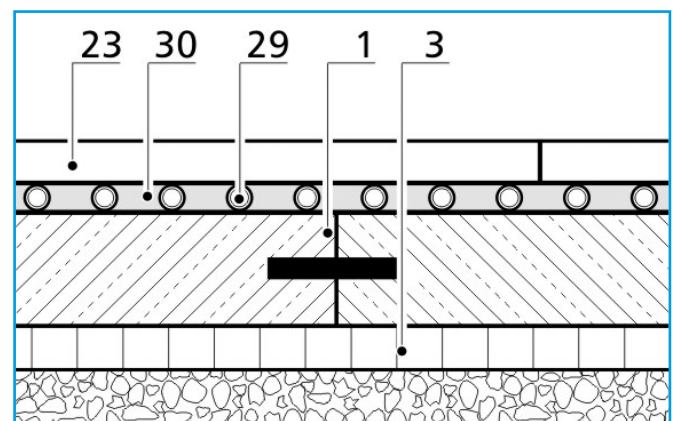
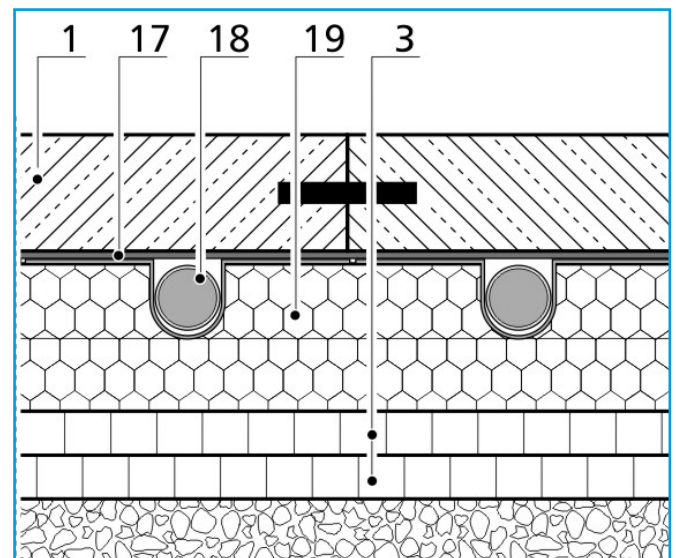
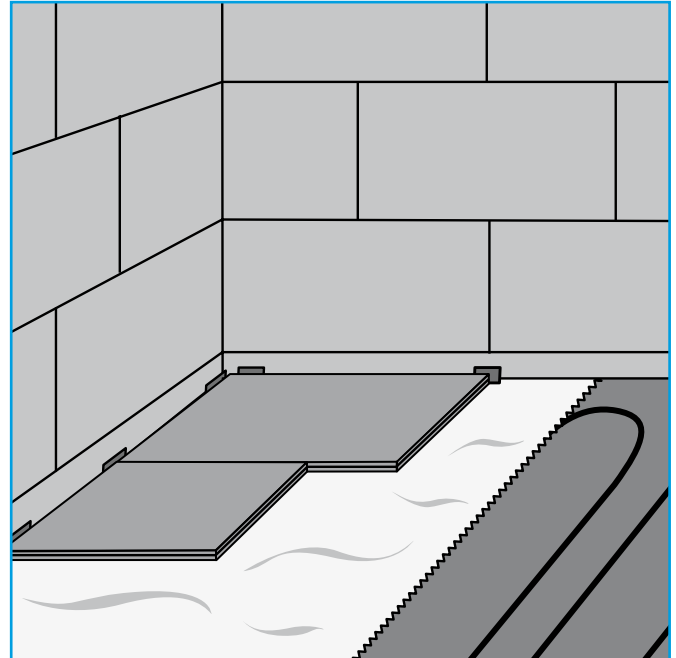

Key

- 1 AQUAPANEL® Cement Board Floor
- 3 Covering board
- 17 Heat-conducting layer or heat-conducting plate
- 18 Heating pipes
- 19 Mould plates made of PS or PUR
- 23 Ceramic covering
- 29 Electric underfloor heating
- 30 Thin adhesive bed

Application fields

Ideal for wood frame builds, prefabricated buildings & refurbishment

Module – Timber beam ceiling with AQUAPANEL® Cement Board Floor

Old timber beam ceilings can be refurbished with AQUAPANEL® Cement Board Floor as follows. Remove any floorboards, backing and false ceilings. Screw load-bearing battens onto the side of the present joists, fit in new false ceiling and provide with barrier as needed. Put fill between the joist and draw off. Lay fibreboard over this. Compact fill with the hand rammer over shuttering panels or chipboard panels laid on top. Apply a second layer of fill and lay a second layer of fibreboard on top. Compact fill over 60 mm above the laid shuttering panels or chipboard panels. Lay AQUAPANEL® Cement Board Floor.

Special notes

- The impact sound reduction measure has been determined on the ceiling test rig with suppressed flanking transmission.
- The fitting of further layers must only be done after due consideration of the load-bearing capacity of the bare ceiling.
- Floor heating systems may be installed underneath AQUAPANEL® Cement Board Floor.
- Installations must be laid directly onto the bare floor, so as long as the 10 mm minimum depth of fill is maintained.
- Fitting floor coverings on the completed dry floor is permitted without any further considerations.

Ceilings are loaded by dry floor as follows	
AQUAPANEL® Cement Board Floor	0.37 kN/m ²
AQUAPANEL® Cement Board Floor MF	0.39 kN/m ²
AQUAPANEL® Levelling Fill*	0.015 kN/m ²
When determining the depth of fill, consider the compaction of the individual fill	
AQUAPANEL® Levelling Fill	10%

* 10 cm (compacted height)

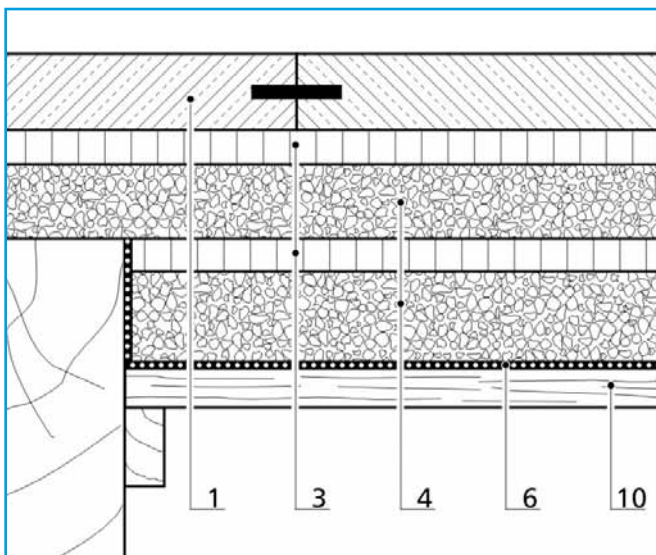

Key

- 1 AQUAPANEL® Cement Board Floor
or, alternatively, AQUAPANEL® Cement Board Floor MF
- 3 Fibreboard
- 4 Fill
- 6 Barrier
- 10 Load-bearing insert



Construction details

AQUAPANEL® Cement Board Floor/MF

Edge joints

Filler and cover boards can be taken up to the edge. An edge joint of at least 10 mm must be maintained between the AQUAPANEL® Cement Board Floor and the adjoining wall. This avoids sound bridges and tensions if the material works due to temperature or moisture fluctuations. An edge insulation strip prevents the joint from filling with adhesive or filler compound from subsequent work. The edge insulation strip must be cut off flush with the upper edge only after laying the final floor covering which is to be walked on. The edge joint is later covered by the skirting board affixed to the wall.

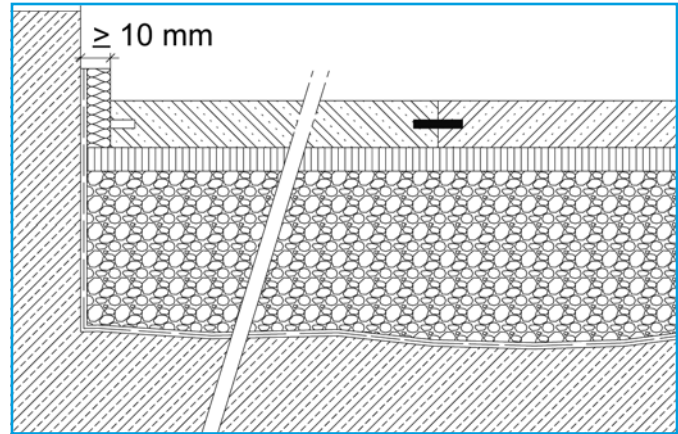

Pipes

Pipes and cables may be laid in dry fill. Additionally, they are fastened to the bare floor. Then the fill is made without any voids. The pipes and cables must be covered by at least 10 mm. Only pipe enclosures made from noncompressible material may be used.

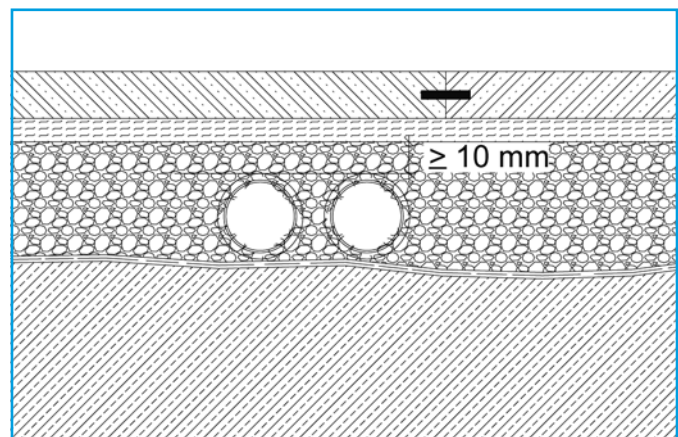

Expansion joints

Construction joints are also incorporated into the dry floor. As AQUAPANEL® Cement Board Floor only has low thermal and hygric extension coefficients, further joints are required only if the length of the side of the room exceeds 10 m. The construction design of the joints should follow a suitable movement profile.

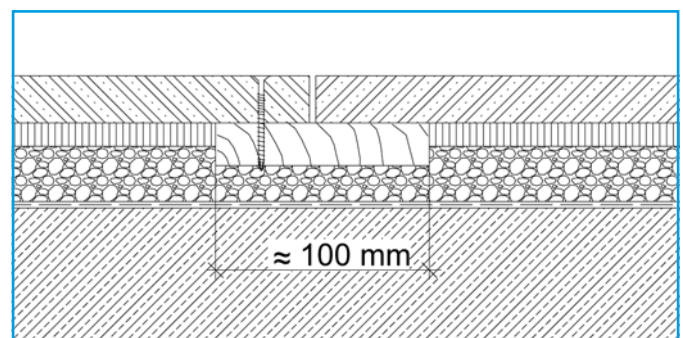
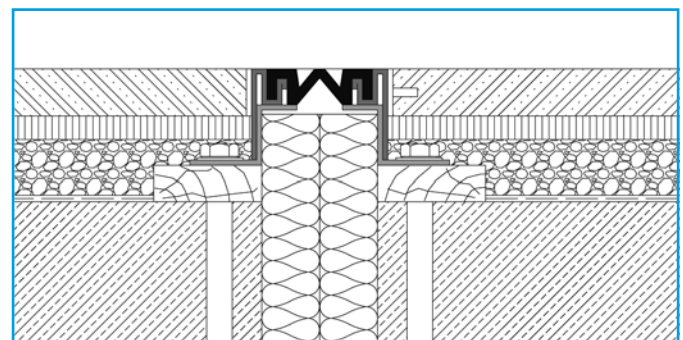

Extreme gradients

If the bare floor has a severe gradient, leave the compaction on the opposite side of the room a bit higher. The reason for this is the percentage compaction of the material in relation to the installed depth. We recommend the following procedure: make a rough equalisation only up to the upper edge of the steel girder underneath the planned installation depth. Level the remaining unevenness after compaction.

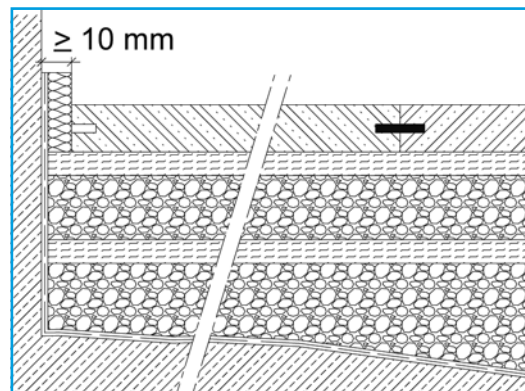

Beamed ceilings

Use AQUAPANEL® Cement Board Floor with cover boards and fill for refurbishing steel girder ceilings. In this case, the minimum depth fill $h = 10 \text{ mm}$ over the upper edge of the steel girder applies.

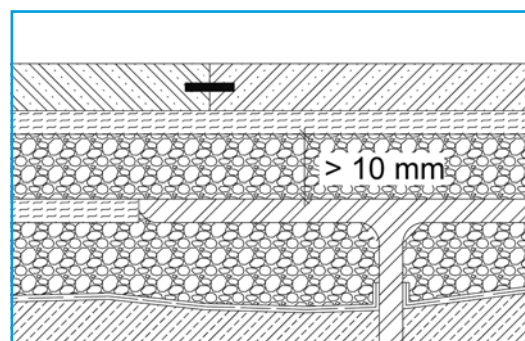

Door sills with stop boards

In the door sill area, you can work with a stop board that separates the various sections of work from each other and prevents the fill from flowing out. The wood must have a width of 80 to 100 mm and be the same height as the finished compacted filling. The cover or impact sound insulation boards run over the wood. To prevent sound being transmitted through the AQUAPANEL® Cement Board Floor, it is butt jointed under the door leaf.

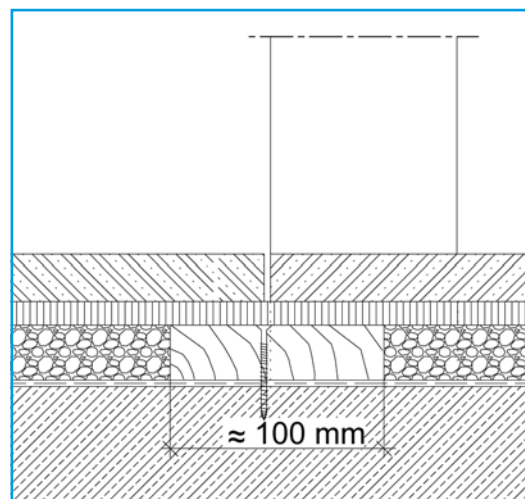

Door sills with stop boards

Alternatively, the fill in the door area can be done if the butt end of the AQUAPANEL® Cement Board Floor is supported in the door area with a piece of wood at least 100 mm wide.

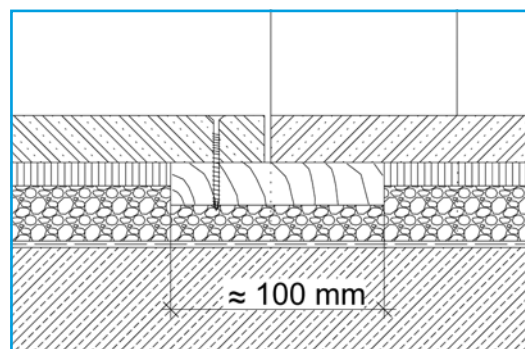

Construction details

AQUAPANEL® Cement Board Floor/MF

Details in damp rooms

Structural works subject to moisture, such as baths, showers and terraces, for example, must be protected against penetration of moisture. National standards must be observed accordingly.

Moisture loading

For floor areas in domestic bathrooms which receive light water spray only briefly and occasionally, only an edge joint needs to be sealed with sealing tape. Depending on the moisture loading, suitable measures must be taken following national standards, codes of practice and recommendations.

Area sealing

Floor areas in bathrooms that receive normal domestic usage with the planned or unplanned use of floor drains, and which receive moderate water spray briefly and occasionally, need to be sealed in accordance with the ZDB Code of Practice. Sealants made of the following materials are suitable for this purpose:

- Polymer dispersions
- Plastic-mortar combinations
- Reaction resins

The quantity of sealant to be applied and the number of layers is determined by the data provided by the manufacturer.

Transition between floor coverings

The transition between tiles and other floor coverings must be flexible and must be secured against any entry of moisture. To do this, the dry screed is intersected down as far as the bare floor by a partition line with inlaid insulation strips. The transition between the floor coverings is done with a suitable profile.

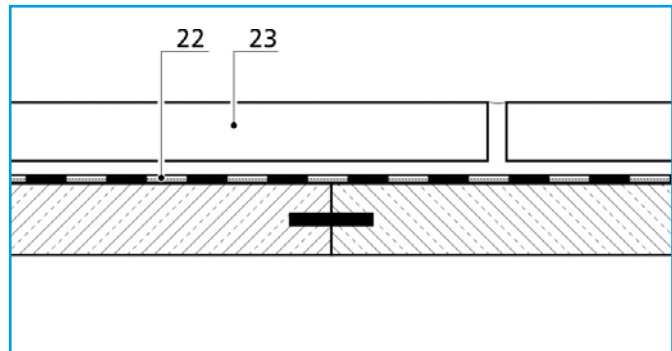

Area sealing

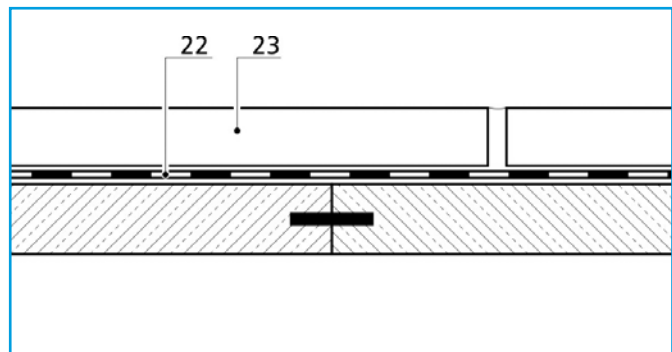

Sealing by sealing strips

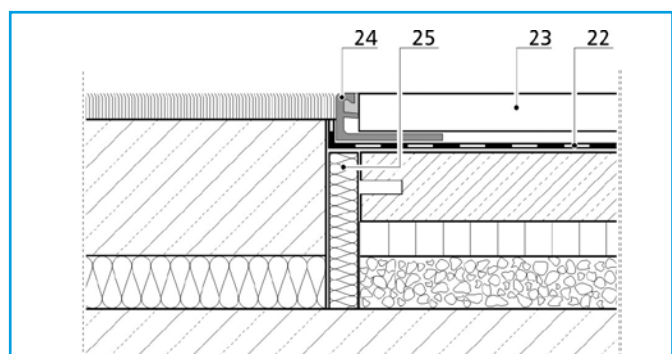

Transition at the same height

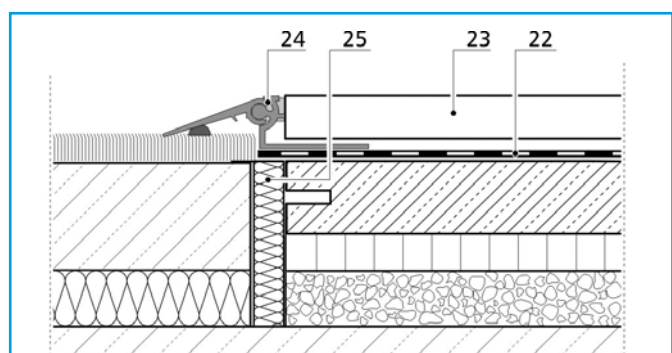

Transition at a different height

Key

- 22 Surface sealing
- 23 Ceramic covering
- 24 Special section
- 25 Edge insulation strips

Edge joints

Filler and cover boards can be taken up to the edge. An edge joint of at least 10 mm with inlaid edge insulation strips is required between AQUAPANEL® Cement Board Floor and the neighbouring wall. An additional sealing band inlay must be arranged in the corner area. It is laid in a loop to be able to accommodate any movement of the components.

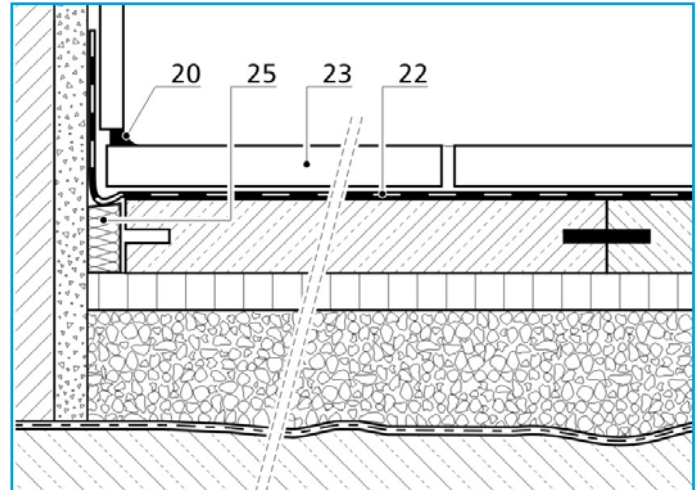

For surface sealings with inlay, there is no need for the sealing strip inlay. In this case the fabric or film is carried in the form of a loop in the corner. The joint between wall and floor covering is closed with a permanently elastic, fungicidal joint filler or a suitable section.

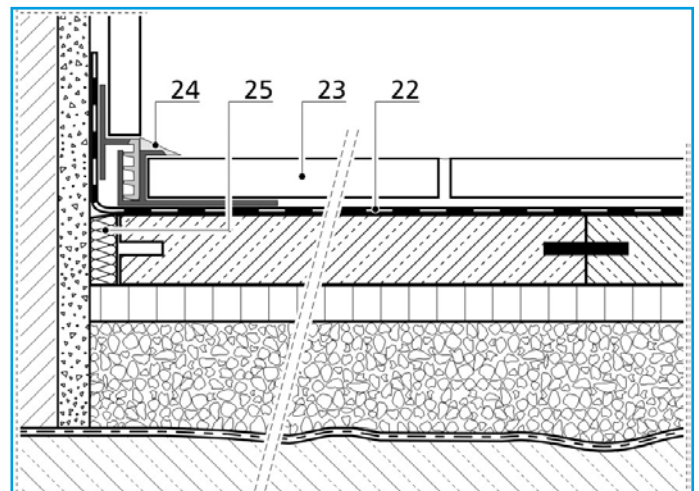

Pipe access

Pipes are provided with a suitable, deformable enclosure.

For construction reasons a pipe collar is fixed above the break-through into the bare ceiling. This pipe collar must be narrow enough to prevent fill material penetrating the opening.

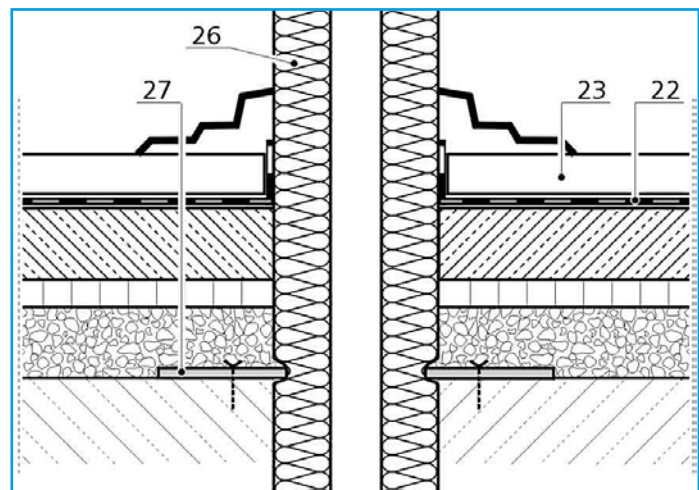

Key

- 20 Elastic, fungicidal joint filler
- 22 Surface sealing
- 23 Ceramic covering
- 24 Special section
- 25 Edge insulation strips
- 26 Pipe enclosure
- 27 Pipe collar



Technical data

AQUAPANEL® Cement Board Floor/MF

Physical properties

Product	AQUAPANEL® Cement Board Floor	AQUAPANEL® Cement Board Floor MF
Length (mm)	900	900
Width (mm)	600	600
Thickness (mm)	22	33
Weight per unit area (kg/m ²)	approx. 37	approx. 39
Dry density (kg/m ³)	approx. 1600	approx. 1600
Flexural strength (N/mm ²)	≥ 3.0	≥ 3.0
Modulus of elasticity (N/mm ²)	4000 – 7000	4000 – 7000
Water vapour permeability (DIN 4108)	70/150	70/150
Thermal conductivity λ (W/mK)	0.79	0.79 (Board) / 0.04 (insulation)
Alkalinity (pH)	12	12
Building Material Class (DIN 4102-1)	A2	A2

Material coverage

Product	Coverage/m ²
AQUAPANEL® Slot Adhesive (PU)	60 ml
AQUAPANEL® Biscuit	approx. 7 pieces
AQUAPANEL® Board Primer	50 g (concentrate); dilution 1:1 with water
AQUAPANEL® Levelling Compound	1.5 kg per layer at thickness of 1 mm ²

Fitting guideline values

Depth of fill	≤ 60 mm		> 60 mm	
	simple	difficult	simple	difficult
	Floor plan and boundary conditions			
Fill plus cover board (min/m ²)	3.5	7.0	5.8	10.5
Fill, cover board plus AQUAPANEL® Cement Board Floor (min/m ²)	13.0	21.0	15.0	26.0



All technical changes reserved. Only the current printed instructions are valid. Our warranty is expressly limited to our products in flawless condition. The constructional and structural properties and characteristic building physics of Knauf systems can solely be ensured with the exclusive use of Knauf system components, or other products expressly recommended by Knauf. All application quantities and delivery amounts are based on empirical data that are not easily transferable to other deviating areas. All rights reserved. All amendments, reprints and photocopies, including those of excerpts, require the express permission of Knauf Aquapanel GmbH & Co. KG, Zur Helle 11, 58638 Iserlohn, Germany. AQUAPANEL® is a registered trademark.

© 2017 EN-03/17



AQUAPANEL®

www.AQUAPANEL.com

AQUAPANEL® Cement Board Floor

Knauf Aquapanel GmbH & Co. KG
Zur Helle 11
58638 Iserlohn
Germany